

Material to Build a *better* Tomorrow.



**Ashka Precem Private Limited**  
**Ashka Premix Industries**

ISO 9001:2015



## **ae** Ashka Precem Private Limited

An ISO 9001:2015 Certified Company, running fully automatic manufacturing plant for a Ready Mix Mortar which was CE certified and selling it under brand name of **ASHKA - PREMIX<sup>+</sup>, TILO<sup>+</sup>, AAC<sup>+</sup>**.

Our Mission is to recognize as a reliable producer and supplier; committed to exceed the expectations of our stake holders through high quality products and services, an efficient multi skilled team focus on our core business and supported by latest technologies.

The company manufactures and supplies Ready Mix Mortar for Masonry, Plaster under the brand name of **ASHKA PREMIX<sup>+</sup>**, for Tiles Fixing in a brand name of **ASHKA TILO<sup>+</sup>** & for Joining mortar of AAC / LLC block in the brand name of **ASHKA AAC<sup>+</sup>**

---

[www.ashkaprecem.com](http://www.ashkaprecem.com)  
[www.ashkapremix.com](http://www.ashkapremix.com)

## Base Material

River  
Sand



## ASHKA PREMIX<sup>+</sup> MASONRY

ASHKA PREMIX+ is a ready mix mortar which is a modified polymer and specially designed to create a superior quality product at a time saving and long lasting durability with cost effective affordability.

MASONRY is specially design for all type of Masonry works held with Clay/Fly ash Bricks, Solid/Hollow Blocks & any type of stone which use in masonry.



1:5 Ratio Mixture (40kg Bag)  
Coverage - 16 sq.ft to 20 sq.ft  
Thickness - 10 mm to 12 mm

**ADMIXTURES/ADDITIVES :** Self Curing Agents • Natural Fibers • Finishing and Bonding Additive

## Base Material

River  
Sand



## ASHKA PREMIX<sup>+</sup> SILVER PLASTER

is a product specifically engineered by our research and development team to produce a high advantageous resulting material which strongly benefits its use in Plastering and Patching of clay & flyash bricks, solid or hollow blocks, AAC blocks and possibly many other uses in the construction and building industry.

SILVER PLASTER is used in Plastering works on Clay/Fly ash Bricks, Solid/Hollow Blocks, & all type of Stone wall or RCC.

### FOR INTERIOR & EXTERIOR



1:4 Ratio Mixture (40kg Bag)  
Coverage - 16 sq.ft to 20 sq.ft  
Thickness - 10 mm to 12 mm

**ADMIXTURES/ADDITIVES** : Self Curing Agents • Natural Fibers • Finishing and Bonding Additive

## Base Material

# River Sand

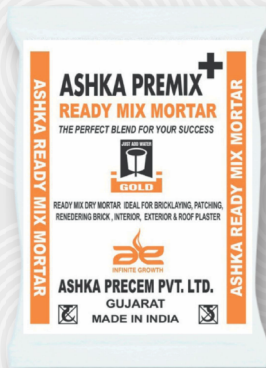

## ASHKA PREMIX<sup>+</sup> GOLD PLASTER

is composition of uniquely designed mix of selected raw materials, it takes far lesser time to cure and retain water comparatively to any other product used in the construction market and therefore making it the Only product in the industry which exceeds the compressive strengths and curing measures set in national standards thus making it one and the only kind of product in its category.

**GOLD PLASTER** is specially design for less curing.

### FOR INTERIOR & EXTERIOR

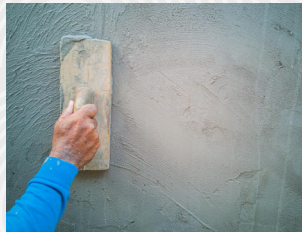

1:4 Ratio Mixture (40kg Bag)

Coverage - 16 sq.ft to 20 sq.ft

Thickness - 10 mm to 12 mm

**ADMIXTURES/ADDITIVES** : Self Curing Agents • Natural Fibers • Finishing and Bonding Additive

Premix<sup>+</sup> GRC Plaster  
How to Make  
your exterior wall  
Beautiful, Strong and

**99.5 %**

**water  
resistant**

**Advantages of GRC PLASTER** 

## What is GRC ?

GRC means **G**lass **R**einforced **C**oncrete

- Glass reinforced concrete (GRC) is a type of concrete that incorporates alkali-resistant fiberglass in place of traditional steel mesh or rebar. This makes the concrete much lighter and more Eco - friendly, without losing any of its strength. Glass reinforced Concrete is increasingly being used for commercial and residential projects. Glass reinforced concrete is a relatively new type of concreting product that can give you more flexibility with your designs while still being as strong as traditional concrete.
- We modified GRC into Water resistant GRC plaster

- Strong & Lightweight
- Eco - friendly
- Durable, Cheaper
- Long lasting
- **Also use for Cladding, Moulds & Landscaping.**

## Where to use ?

- Use at new construction building Exterior Wall Plaster, for best result apply 2 coat of plaster,
  - 1<sup>st</sup> is GRC Base Coat and
  - 2<sup>nd</sup> is Premix+ GRC Top Coat
- Also use for repair work of Interior and Exterior walls, to fill the cracks, joints and re plastering work.
- GRC plaster also use for prefabricated cladding work.
- GRC plaster is a cost effective option for creating intricate architectural features that are lightweight and corrosion free.
- GRC is as hard wearing as standard concrete, it used in many locations outdoors, from seating to garden ornaments.



## How to use

Premix<sup>+</sup> GRC Plaster  
for getting 99.50% water resistant  
of exterior wall

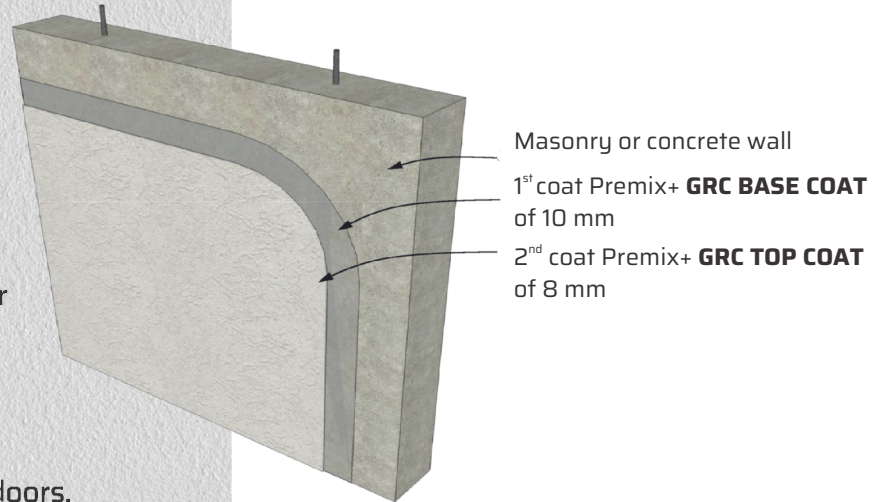

## Direction for use

1



Clean the surface from oil, dust, bound inhibiting agents

2



Add water approximately 15 to 17 ltrs. per bag

3



Mix mortar properly for better result

4



Wait 2 to 3 min. to dissolve the additives

5



Curing after 24 hours, 2 times per day for 5 days

## BENEFITS

- Easy to use
- Fibre reinforced
- Higher binding capacity
- Durable finish
- Increase water retention
- Less curing required
- Provide ultimate strength
- Superior elasticity to bound all materials
- Smooth plaster which spread uniformity
- Reduce wastage
- Improve labour productivity hence reduce cost
- Time saving
- Increase life span
- Less chance of crack development



# CERTIFICATION & PRODUCT TEST REPORT



Ref:SGS/AHD/INDLAB/0787-D/18

Date:05/10/18

## TEST REPORT MORTAR CUBE TESTING

Name of Client: Ashka Precem Pvt. Ltd.  
 Address of Client: Umiya Bhuvan, Plot No. 62, Sector - 7, Gandhidham, Katch.  
 Ref: Letter dated 06/09/18  
 Name of Work: Manufacturing Unit, R.S. No: 820/1, Village-Versamed, Khara Paswaria Road, Ta.- Anjar, Kutch, Gujarat.  
 Details of Sample: Dry Ready Mix Plaster, Brand Name: Ashka Premix+ Silver.  
 Condition of Sample: Sealed Bag  
 Sample Inward No.: INDLAB/2018/0787  
 JDE No.: 0787  
 Received Date: 06-09-2018  
 Testing Started On: 05-10-2018  
 Testing Completed On: 05-10-2018  
 Tested as per: IS:2250:1981

### RESULTS:

Sr. No.	Description	Date of Casting	Date of Testing	Load (KN)	Area (mm <sup>2</sup> )	Compressive Strength (N/mm <sup>2</sup> )	Average Comp. Strength (N/mm <sup>2</sup> )
1	C.M.Cube	07-09-18	05-10-18	43.10	2530.1	17.0	19.9
2	C.M.Cube	07-09-18	05-10-18	38.12	2490.0	15.3	
3	C.M.Cube	07-09-18	05-10-18	38.54	2530.1	15.2	

Note: Compressive Strength Test carried out at above sample without water curing as per request of client.

### RESULTS:

Sr. No.	Description	Date of Casting	Date of Testing	Load (KN)	Area (mm <sup>2</sup> )	Compressive Strength (N/mm <sup>2</sup> )	Average Comp. Strength (N/mm <sup>2</sup> )
1	C.M.Cube	07-09-18	05-10-18	46.44	2530.0	18.4	18.4
2	C.M.Cube	07-09-18	05-10-18	45.12	2500.0	18.0	
3	C.M.Cube	07-09-18	05-10-18	47.40	2530.1	18.7	

Note: Compressive Strength Test carried out at above sample with regular water curing as per IS 2250:1981.

- The results are related to the sample/s tested only.
- Above mentioned details regarding Grade, Casting date and description are declared by Client.
- This Test Report shall not be reproduced except in full, without the written approval of SGS INDIA PRIVATE LTD.
- No samples will be retained without any request by client at the time of submitting the sample.
- Sample not drawn by SGS India Pvt. Ltd.
- Mortar cube (50\*50\*50 mm) casted at laboratory by using 15% water by weight of dry mortar at the flow 113% as per IS:2250.

For SGS India Pvt. Ltd.  
*B. N. Dhanraj*  
 (Authorized Signatory)

Lab: Shop No.2, Basement, Agrawal Mill, Opp. Sola Bhagwat VidyaPath, S.G. Highway, Ahmedabad - 380054. (Ph): 9033021588

SGS India Private Ltd | 201, 2nd Floor, Saralika, Near Guruwara, S.G. Highway, Ahmedabad - 380 054 t: (91-79) 6160 3160 6 6060 8747 f: (91-79) 6160 3111

(Checked by)

## ASHKA TILO<sup>+</sup> COPPER

**ASHKA TILO<sup>+</sup>** is a Tiles fixing mortar specially designed to create a superior quality product at a time saving and long lasting durability with cost effective affordability.



Class	Characteristic
<b>CO</b>	<b>COMPLIANT WITH EN12004 STANDARD</b>

**For all kinds of  
CERAMIC WALL & FLOOR TILES**

FLOOR 40kg Bag

Coverage : 20 sq.ft to 22 sq.ft

Thickness : 10 mm to 12 mm

Floor Fixing Tile : 600mm x 600mm

# ASHKA TILO<sup>+</sup> Silver (Grey)

For Interior use only.

ASHKA TILO<sup>+</sup> Silver is Polymer modified cement based tile adhesive.



Fix it.. *Forever*



Class	Characteristic
<b>C1</b>	<b>T</b>
COMPLIANT WITH EN12004 STANDARD	

For all kinds of

- CERAMIC/VITRIFIED/  
WALL/FLOOR TILES
- TILE ON TILE

SILVER (GREY BASE)

- 20kg Bag
- 40kg Bag (Project Pack)

Coverage per 20 kg : 20 sq.ft to 22 sq.ft

Thickness : 4mm to 5mm

Fixing the Tile Upto : **600mm X 600mm**

# ASHKA TILO<sup>+</sup> Gold (Grey / White)

For Interior & Exterior

**ASHKA TILO<sup>+</sup> Gold** is Polymer modified cement based tile adhesive.

- Available in 2 variant Grey & White



Fix it.. *Forever*



Class	Characteristic
<b>C1</b>	<b>TE</b>
COMPLIANT WITH EN12004 STANDARD	

For all kinds of

- VITRIFIED / WALL / FLOOR TILES**
- GRANITE DOOR AND WINDOW FRAME**

GOLD 20kg Bag

- Coverage : 20 sq.ft to 22 sq.ft
- Thickness : 4mm to 5mm

Fixing the tile height upto 12 feet :

- Interior : 1200mm x 1200mm**
- Exterior : 600mm x 600mm**

# ASHKA TILO<sup>+</sup> Platinum (Grey / White)

For Interior & Exterior

ASHKA TILO<sup>+</sup> Platinum is Polymer modified cement based tile adhesive.

- Available in 2 variant Grey & White

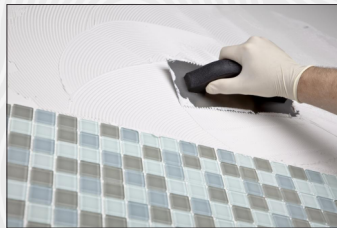

Fix it.. *Forever*



Class	Characteristic
<b>C2</b>	<b>TE</b>
COMPLIANT WITH EN12004 STANDARD	

**For all kinds of  
VITRIFIED / QUARTZ STONE**

PLATINUM 20kg Bag

Coverage : 20 sq.ft to 22 sq.ft

Thickness : 4mm to 5mm

Fixing the Tile height upto 15 feet

- Interior : 1200mm x 2400mm
- Exterior : 1800mm x 900mm

## BLOCK JOINING MORTAR

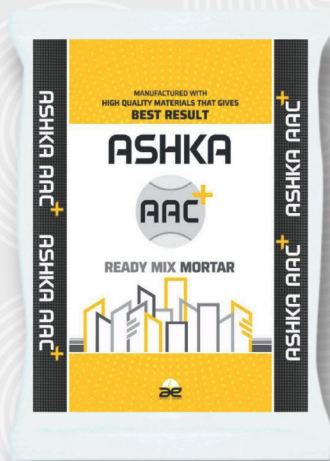

## ASHKA AAC<sup>+</sup> Block Binder

ASHKA AAC+ is a one of kind product specifically engineered by our research and development team to produce a highly advantageous resulting material which strongly benefits its use in Joining of AAC & ALC blocks.



### USEFUL FOR MASONRY OF All kinds of AUTOCLAVED AERATED CONCRETE BLOCKS

#### AAC BINDER PACKING

- 20 kg Bag
- 40 kg Bag (Project Pack)
- Coverage : 12sq.ft to 14sq.ft
- Thickness : 8 mm to 10 mm

# ASHKA TILO<sup>+</sup> TILE GROUT



A high quality fine polymer modified, water-resistant cement based powder grout designed for grouting glaze wall tiles, mosaics, vitrified & fully vitrified tiles, floor tiles etc.

TILO+ grout provide a tile Joint that is strong, Hard, durable & colour fast.  
Ideal for tile joint 1 mm to 3 mm.

Available in 20 colours.



## Packing

- 1 Kg. Pouch Pack
- 25 Kg. Project Pack
- Coloured Grout Polymer Grout Colours.
- German Technology.
- Self Life Upto 2 years.

# ASHKA TILO<sup>+</sup> STAIN FREE EPOXY GROUT



TILO+ is a solvent free epoxy grout, offering a unique combination of features and benefits. It has high compressive, flexural and shear adhesion strength.

TILO+ is resistant to several acids, alkalis, corrosive agents for concrete, cleaning agents, sea water and salted water. It has excellent workability for flooring applications and is easily cleaned with water before hardening. It is designed for grouting gaps ranging from 1.5mm-15mm.

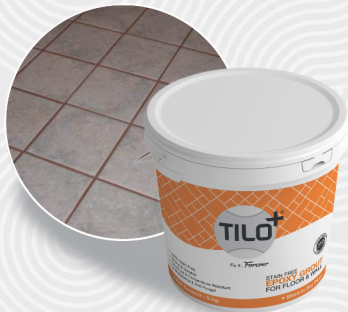

MIXTURE

**3 COMPONENTS**

Shelf Life

**24 Months**

**1kg** (300Gms. Resin Kit + 700Gms. Filler)

**5kg** (1.5Kg. Resin Kit + 3.5Kg. Filler)

- 100% Stain Free
- Strong and Durable.
- Anti-Bacterial and Anti-Fungal.
- Chemical and Temperature Resistant.



## ASHKA TILO<sup>+</sup> TILE SPACERS, WEDGES, CLIPS & PLIER.

### AVAILABLE

- SPACERS SIZES (in millimeter) :  
2-3-4-5-6-10
- CLIPS SIZES : 2-3-4
- WEDGES SIZE : FREE SIZE
- TILES LAVELLING JACK-2MM

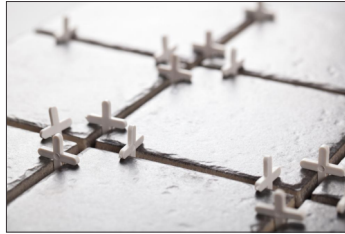

## ASHKA TILO<sup>+</sup> TILE PROTECTION SHEET

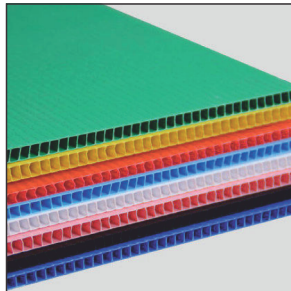

Tile Protection Sheet is very easy to apply and reusable multiple times. It has very high impact resistance and keeps the workspace clean. Time saving, cost effective and reliable Easy to cut to preferred size Waterproof

### AVAILABLE

GREY / WHITE COLOUR | 6' X 4' SIZE | 2mm & 3mm THICKNESS

## OUR VALUABLE CLIENTS



## OUR PRESENCE IN INDIA



### **ASHKA PRECEM PVT. LTD. ASHKA PREMIX INDUSTRIES**

currently we are supplying to more than six states.

In the recent years our dealers network growth provided us to reach every location covered as per market competition we are ahead as we provide quality products at effective rate.





## Ashka Precem Pvt. Ltd. Ashka Premix Industries

ISO 9001:2015

Material to Build a *Better* Tomorrow.



### Gujarat Head Office

#### Ashka Precem private Limited

1, Umiya Bhuvan, Plot No. 62, Sector No. 7,  
Gandhidham-370 201, Kutch, Gujarat-India.

Contact : +91 7041333300

E-Mail : [ashka.precem@gmail.com](mailto:ashka.precem@gmail.com)



### Maharashtra Head Office

#### Ashka Premix Industries

C/o Kailash Timber Mart, Kailash Nagar Road.

Aurangabad-431001, Maharashtra

Contact : +91 9850329097

E-Mail : [ashkapremix@gmail.com](mailto:ashkapremix@gmail.com)

E-Mail : [arun\\_r\\_patel@hotmail.com](mailto:arun_r_patel@hotmail.com)



### Karnatka Head Office

#### Ashka Precem Private Limited

Plot No. 114/A, Honga Industries Area,

Honga-Belgavi-590011, Karnataka

Contact : +91 7041333300

E-Mail : [ashka.precem@gmail.com](mailto:ashka.precem@gmail.com)

Website : [www.ashkaprecem.com](http://www.ashkaprecem.com)  
[www.ashkapremix.com](http://www.ashkapremix.com)



### Unit-1

#### Ashka Precem Private Limited

Revenue Survey No - 820/1, Village - Versamedi,  
Anjar, Kutch - Gujarat - 370110.



### Unit-2

#### Ashka Precem Private Limited

Revenue Survey No - 962, Village - Sitapure,  
Dabhoi, Vadodara, Gujarat-391110.



### Unit-3

#### Ashka Premix Industries

Plot No. C-2, Near Fire Brigade,  
Shendra Five Star MIDC Aurangabad-431154,  
Maharashtra



### Unit-4

#### Ashka Precem Private Limited

Plot No. 114/A, Honga Industries Area,  
Honga-Belgavi-590011, Karnataka